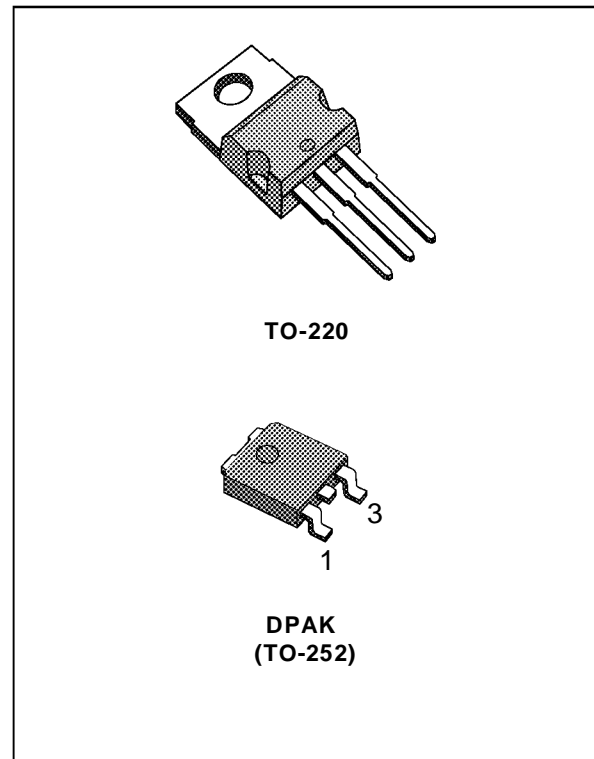


**PRECISION 500mA REGULATORS**

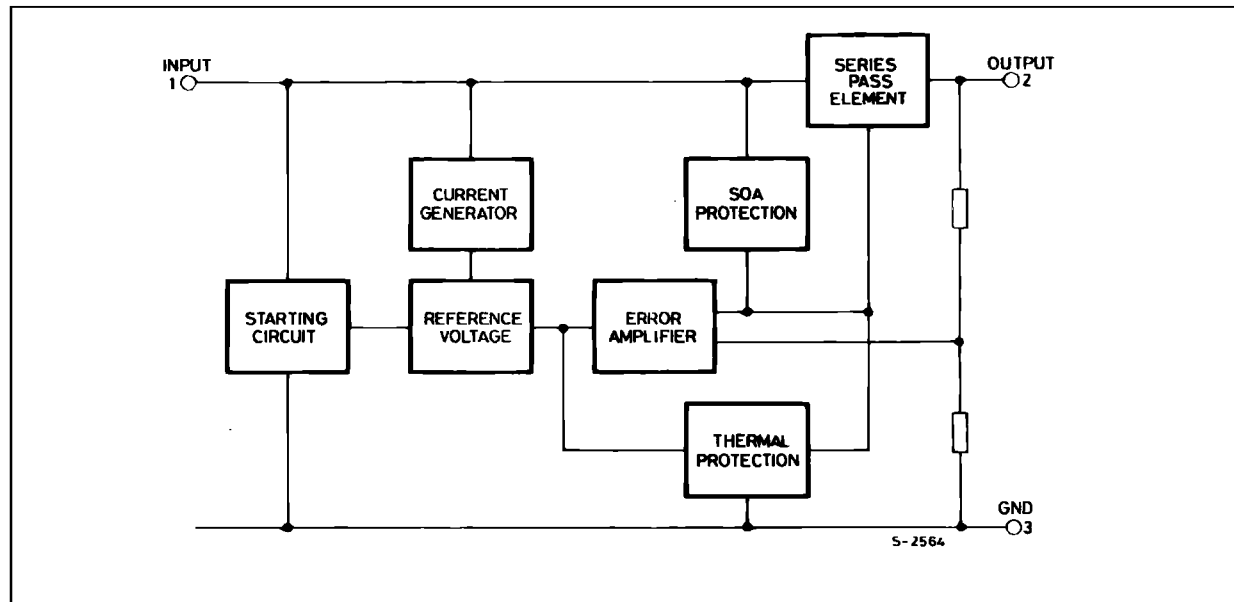
- OUTPUT CURRENT UP TO 0.5A
- OUTPUT VOLTAGES OF 5; 6; 8; 9; 10; 12; 15; 18; 20; 24V
- THERMAL OVERLOAD PROTECTION
- SHORT CIRCUIT PROTECTION
- OUTPUT TRANSISTORS SOA PROTECTION
- $\pm 2\%$  OUTPUT VOLTAGE TOLERANCE
- GUARANTEED IN EXTENDED TEMPERATURE RANGES

**DESCRIPTION**

The L78M00AB series of three-terminal positive regulators is available in TO-220 and DPAK packages and with several fixed output voltages, making it useful in a wide range of applications. These regulators can provide local on-card regulation eliminating the distribution problems associated with single point regulation. Each type employs internal current limiting, thermal shut-down and safe area protection, making it essentially indestructible. If adequate heat sinking is provided, they can deliver over 0.5A output current. Although designed primarily as fixed voltage regulators, these devices can be used with external components to obtain adjustable voltages and currents.



**BLOCK DIAGRAM**



## L78M00AB/AC SERIES

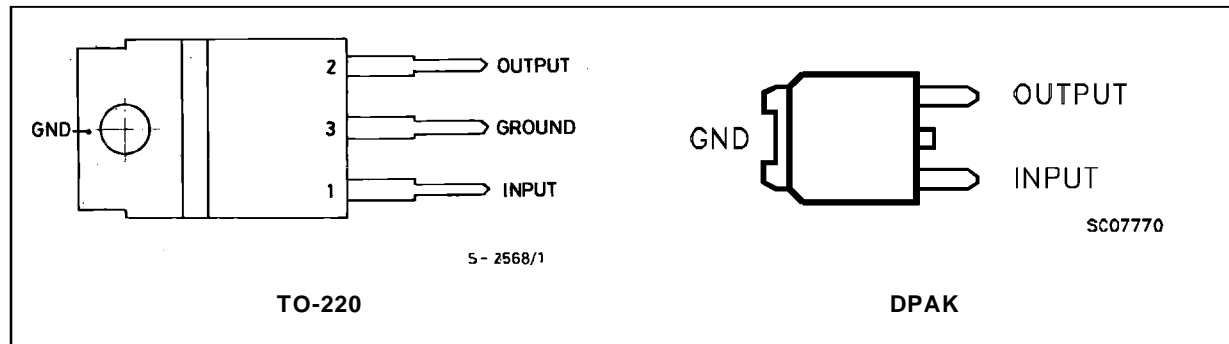
### ABSOLUTE MAXIMUM RATINGS

Symbol	Parameter	Value	Unit
$V_i$	DC Input Voltage (for $V_o = 5$ to 18V) (for $V_o = 20, 24V$ )	35	V
		40	V
$I_o$	Output Current	Internally Limited	
$P_{tot}$	Power Dissipation	Internally Limited	
$T_{stg}$	Storage Temperature	-65 to 150	°C
$T_j$	Operating Junction Temperature for L78M00AC L78M00AB	0 to 125	°C
		-40 to 125	°C

### THERMAL DATA

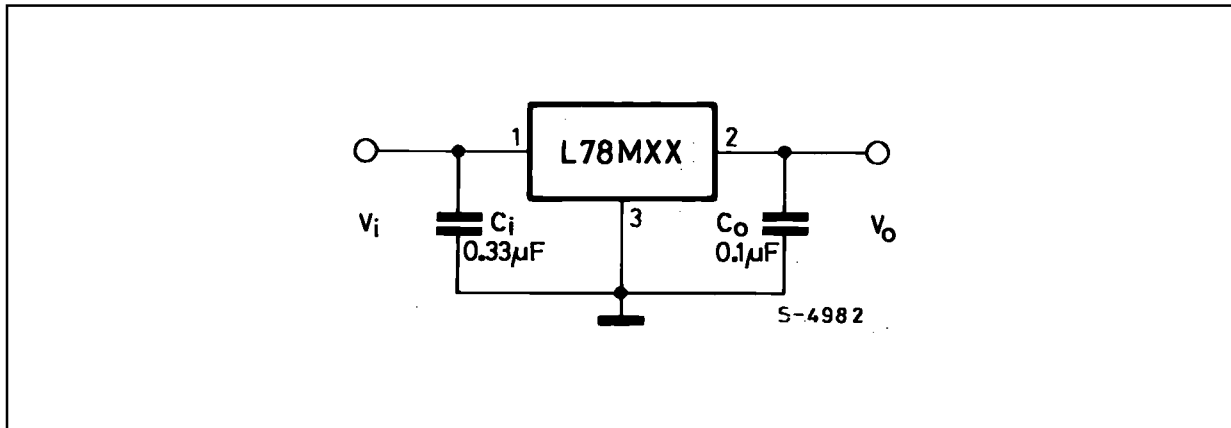
			TO-220	DPAK	
$R_{thj-case}$	Thermal Resistance Junction-case	MAX	3	8	°C/W
$R_{thj-amb}$	Thermal Resistance Junction-ambient	MAX	50	100	°C/W

### CONNECTION DIAGRAM AND ORDER CODES (top view)

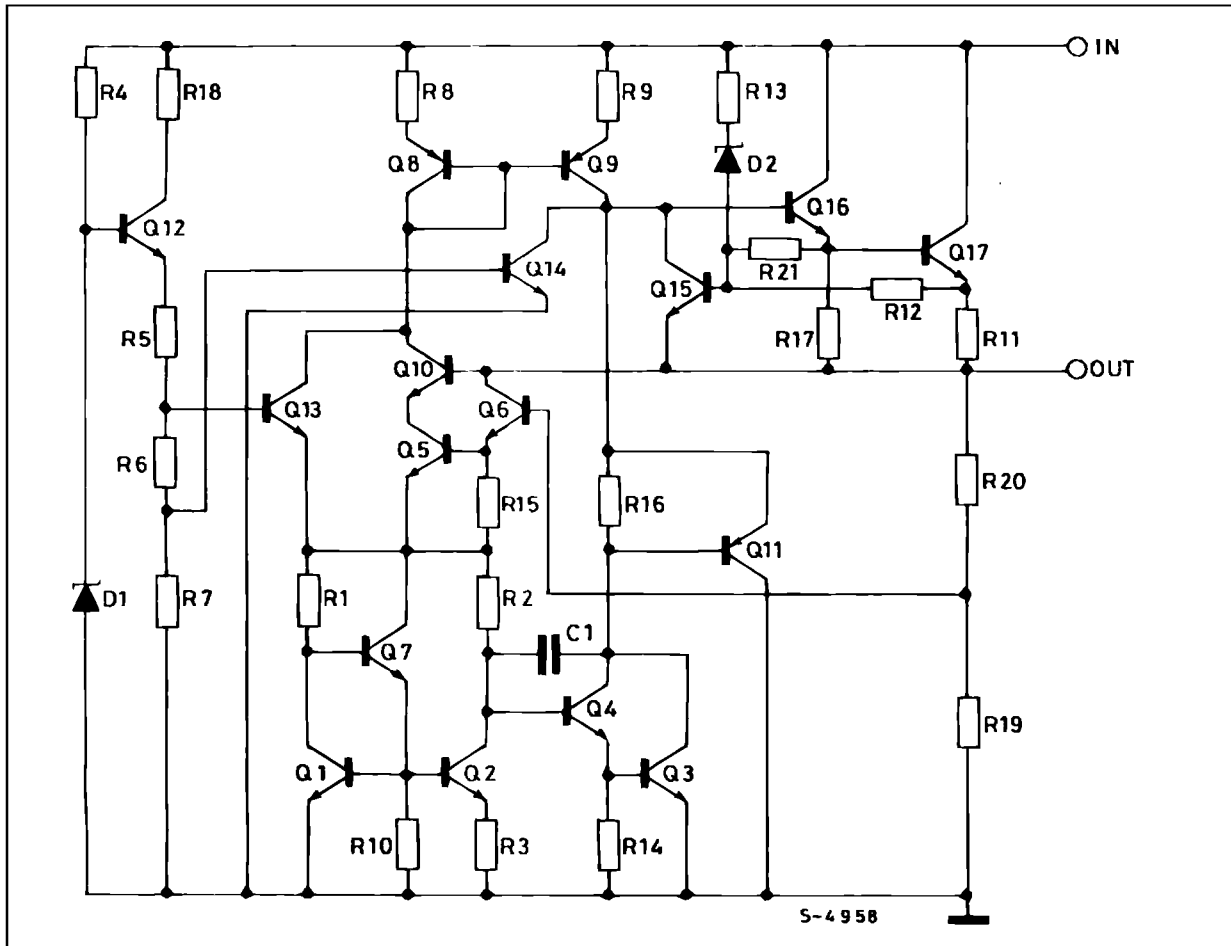


Order Codes			Output Voltage
0 to 125 °C	-40 to 125 °C		
DPAK	TO-220	DPAK	
L78M05ACDT	L78M05ABV	L78M05ABDT	5V
L78M06ACDT	L78M06ABV	L78M06ABDT	6V
L78M08ACDT	L78M08ABV	L78M08ABDT	8V
L78M09ACDT	L78M09ABV	L78M09ABDT	9V
L78M10ACDT	L78M10ABV	L78M10ABDT	10V
L78M12ACDT	L78M12ABV	L78M12ABDT	12V
L78M15ACDT	L78M15ABV	L78M15ABDT	15V
L78M18ACDT	L78M18ABV	L78M18ABDT	18V
L78M20ACDT	L78M20ABV	L78M20ABDT	20V
L78M24ACDT	L78M24ABV	L78M24ABDT	24V

APPLICATION CIRCUIT



SCHEMATIC DIAGRAM



# L78M00AB/AC SERIES

## TEST CIRCUITS

Figure 1 : DC Parameters.

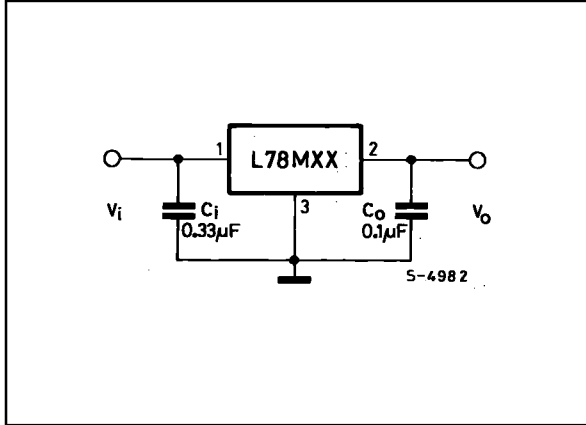


Figure 2 : Load Regulation.

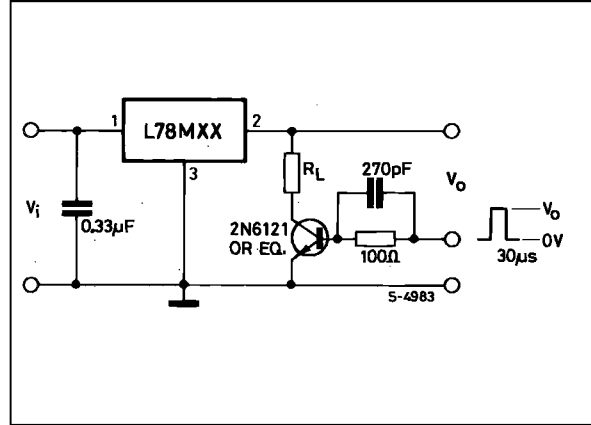
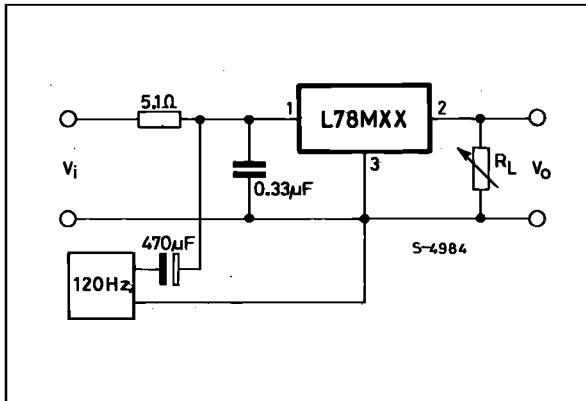


Figure 3 : Ripple Rejection.



## L78M00AB/AC SERIES

**ELECTRICAL CHARACTERISTICS FOR L78M05XX** (refer to the test circuits,  $V_i = 10V$ ,  $I_o = 350\text{ mA}$ ,  $C_i = 0.33\ \mu\text{F}$ ,  $C_o = 0.1\ \mu\text{F}$ ,  $T_j = -40\text{ to }125\text{ }^\circ\text{C}$  (AB),  $T_j = 0\text{ to }125\text{ }^\circ\text{C}$  (AC) unless otherwise specified)

Symbol	Parameter	Test Conditions	Min.	Typ.	Max.	Unit
$V_o$	Output Voltage	$T_j = 25\text{ }^\circ\text{C}$	4.9	5	5.1	V
$V_o$	Output Voltage	$I_o = 5\text{ mA to }350\text{ mA}$ $V_i = 7\text{ to }20\text{ V}$	4.8	5	5.2	V
$\Delta V_o$	Line Regulation	$I_o = 200\text{ mA}$ $T_j = 25\text{ }^\circ\text{C}$ $V_i = 7\text{ to }25\text{ V}$ $V_i = 8\text{ to }25\text{ V}$			100 30	mV mV
$\Delta V_o$	Load Regulation	$I_o = 5\text{ to }500\text{ mA}$ $T_j = 25\text{ }^\circ\text{C}$ $I_o = 5\text{ to }200\text{ mA}$ $T_j = 25\text{ }^\circ\text{C}$			100 50	mV mV
$I_d$	Quiescent Current	$T_j = 25\text{ }^\circ\text{C}$			6	mA
$\Delta I_d$	Quiescent Current Change	$I_o = 5\text{ to }350\text{ mA}$			0.5	mA
$\Delta I_d$	Quiescent Current Change	$I_o = 200\text{ mA}$ $V_i = 8\text{ to }25\text{ V}$			0.8	mA
$\frac{\Delta V_o}{\Delta T}$	Output Voltage Drift	$I_o = 5\text{ mA}$		-0.5		mV/ $^\circ\text{C}$
$e_N$	Output Noise Voltage	$B = 10\text{Hz to }100\text{KHz}$ $T_j = 25\text{ }^\circ\text{C}$		40		$\mu\text{V}$
SVR	Supply Voltage Rejection	$I_o = 300\text{ mA}$ $f = 120\text{ Hz}$ $T_j = 25\text{ }^\circ\text{C}$ $V_i = 8\text{ to }18\text{ V}$	62			dB
$V_d$	Dropout Voltage	$T_j = 25\text{ }^\circ\text{C}$		2		V
$I_{sc}$	Short Circuit Current	$T_j = 25\text{ }^\circ\text{C}$ $V_i = 35\text{ V}$		300		mA
$I_{scp}$	Short Circuit Peak Current	$T_j = 25\text{ }^\circ\text{C}$		700		mA

**ELECTRICAL CHARACTERISTICS FOR L78M06XX** (refer to the test circuits,  $V_i = 11V$ ,  $I_o = 350\text{ mA}$ ,  $C_i = 0.33\ \mu\text{F}$ ,  $C_o = 0.1\ \mu\text{F}$ ,  $T_j = -40\text{ to }125\text{ }^\circ\text{C}$  (AB),  $T_j = 0\text{ to }125\text{ }^\circ\text{C}$  (AC) unless otherwise specified)

Symbol	Parameter	Test Conditions	Min.	Typ.	Max.	Unit
$V_o$	Output Voltage	$T_j = 25\text{ }^\circ\text{C}$	5.88	6	6.12	V
$V_o$	Output Voltage	$I_o = 5\text{ mA to }350\text{ mA}$ $V_i = 8\text{ to }21\text{ V}$	5.75	6	6.3	V
$\Delta V_o$	Line Regulation	$I_o = 200\text{ mA}$ $T_j = 25\text{ }^\circ\text{C}$ $V_i = 8\text{ to }25\text{ V}$ $V_i = 9\text{ to }25\text{ V}$			100 30	mV mV
$\Delta V_o$	Load Regulation	$I_o = 5\text{ to }500\text{ mA}$ $T_j = 25\text{ }^\circ\text{C}$ $I_o = 5\text{ to }200\text{ mA}$ $T_j = 25\text{ }^\circ\text{C}$			120 60	mV mV
$I_d$	Quiescent Current	$T_j = 25\text{ }^\circ\text{C}$			6	mA
$\Delta I_d$	Quiescent Current Change	$I_o = 5\text{ to }350\text{ mA}$			0.5	mA
$\Delta I_d$	Quiescent Current Change	$I_o = 200\text{ mA}$ $V_i = 9\text{ to }25\text{ V}$			0.8	mA
$\frac{\Delta V_o}{\Delta T}$	Output Voltage Drift	$I_o = 5\text{ mA}$		-0.5		mV/ $^\circ\text{C}$
$e_N$	Output Noise Voltage	$B = 10\text{Hz to }100\text{KHz}$ $T_j = 25\text{ }^\circ\text{C}$		45		$\mu\text{V}$
SVR	Supply Voltage Rejection	$I_o = 300\text{ mA}$ $f = 120\text{ Hz}$ $T_j = 25\text{ }^\circ\text{C}$ $V_i = 9\text{ to }19\text{ V}$	59			dB
$V_d$	Dropout Voltage	$T_j = 25\text{ }^\circ\text{C}$		2		V
$I_{sc}$	Short Circuit Current	$T_j = 25\text{ }^\circ\text{C}$ $V_i = 35\text{ V}$		270		mA
$I_{scp}$	Short Circuit Peak Current	$T_j = 25\text{ }^\circ\text{C}$		700		mA

## L78M00AB/AC SERIES

**ELECTRICAL CHARACTERISTICS FOR L78M08XX** (refer to the test circuits,  $V_i = 14V$ ,  $I_o = 350\text{ mA}$ ,  $C_i = 0.33\ \mu\text{F}$ ,  $C_o = 0.1\ \mu\text{F}$ ,  $T_j = -40\text{ to }125\text{ }^\circ\text{C}$  (AB),  $T_j = 0\text{ to }125\text{ }^\circ\text{C}$  (AC) unless otherwise specified)

Symbol	Parameter	Test Conditions	Min.	Typ.	Max.	Unit
$V_o$	Output Voltage	$T_j = 25\text{ }^\circ\text{C}$	7.84	8	8.16	V
$V_o$	Output Voltage	$I_o = 5\text{ mA to }350\text{ mA}$ $V_i = 10.5\text{ to }23\text{ V}$	7.7	8	8.3	V
$\Delta V_o$	Line Regulation	$I_o = 200\text{ mA}$ $T_j = 25\text{ }^\circ\text{C}$ $V_i = 10.5\text{ to }25\text{ V}$ $V_i = 11\text{ to }25\text{ V}$			100 30	mV mV
$\Delta V_o$	Load Regulation	$I_o = 5\text{ to }500\text{ mA}$ $T_j = 25\text{ }^\circ\text{C}$ $I_o = 5\text{ to }200\text{ mA}$ $T_j = 25\text{ }^\circ\text{C}$			160 80	mV mV
$I_d$	Quiescent Current	$T_j = 25\text{ }^\circ\text{C}$			6	mA
$\Delta I_d$	Quiescent Current Change	$I_o = 5\text{ to }350\text{ mA}$			0.5	mA
$\Delta I_d$	Quiescent Current Change	$I_o = 200\text{ mA}$ $V_i = 10.5\text{ to }25\text{ V}$			0.8	mA
$\frac{\Delta V_o}{\Delta T}$	Output Voltage Drift	$I_o = 5\text{ mA}$		-0.5		mV/ $^\circ\text{C}$
$e_N$	Output Noise Voltage	$B = 10\text{Hz to }100\text{KHz}$ $T_j = 25\text{ }^\circ\text{C}$		52		$\mu\text{V}$
SVR	Supply Voltage Rejection	$I_o = 300\text{ mA}$ $f = 120\text{ Hz}$ $T_j = 25\text{ }^\circ\text{C}$ $V_i = 11.5\text{ to }21.5\text{ V}$	56			dB
$V_d$	Dropout Voltage	$T_j = 25\text{ }^\circ\text{C}$		2		V
$I_{sc}$	Short Circuit Current	$T_j = 25\text{ }^\circ\text{C}$ $V_i = 35\text{ V}$		250		mA
$I_{scp}$	Short Circuit Peak Current	$T_j = 25\text{ }^\circ\text{C}$		700		mA

**ELECTRICAL CHARACTERISTICS FOR L78M09XX** (refer to the test circuits,  $V_i = 15V$ ,  $I_o = 350\text{ mA}$ ,  $C_i = 0.33\ \mu\text{F}$ ,  $C_o = 0.1\ \mu\text{F}$ ,  $T_j = -40\text{ to }125\text{ }^\circ\text{C}$  (AB),  $T_j = 0\text{ to }125\text{ }^\circ\text{C}$  (AC) unless otherwise specified)

Symbol	Parameter	Test Conditions	Min.	Typ.	Max.	Unit
$V_o$	Output Voltage	$T_j = 25\text{ }^\circ\text{C}$	8.82	9	9.18	V
$V_o$	Output Voltage	$I_o = 5\text{ mA to }350\text{ mA}$ $V_i = 11.5\text{ to }24\text{ V}$	8.64	9	9.36	V
$\Delta V_o$	Line Regulation	$I_o = 200\text{ mA}$ $T_j = 25\text{ }^\circ\text{C}$ $V_i = 11.5\text{ to }25\text{ V}$ $V_i = 12\text{ to }25\text{ V}$			100 30	mV mV
$\Delta V_o$	Load Regulation	$I_o = 5\text{ to }500\text{ mA}$ $T_j = 25\text{ }^\circ\text{C}$ $I_o = 5\text{ to }200\text{ mA}$ $T_j = 25\text{ }^\circ\text{C}$			180 90	mV mV
$I_d$	Quiescent Current	$T_j = 25\text{ }^\circ\text{C}$			6	mA
$\Delta I_d$	Quiescent Current Change	$I_o = 5\text{ to }350\text{ mA}$			0.5	mA
$\Delta I_d$	Quiescent Current Change	$I_o = 200\text{ mA}$ $V_i = 11.5\text{ to }25\text{ V}$			0.8	mA
$\frac{\Delta V_o}{\Delta T}$	Output Voltage Drift	$I_o = 5\text{ mA}$		-0.5		mV/ $^\circ\text{C}$
$e_N$	Output Noise Voltage	$B = 10\text{Hz to }100\text{KHz}$ $T_j = 25\text{ }^\circ\text{C}$		52		$\mu\text{V}$
SVR	Supply Voltage Rejection	$I_o = 300\text{ mA}$ $f = 120\text{ Hz}$ $T_j = 25\text{ }^\circ\text{C}$ $V_i = 12.5\text{ to }23\text{ V}$	56			dB
$V_d$	Dropout Voltage	$T_j = 25\text{ }^\circ\text{C}$		2		V
$I_{sc}$	Short Circuit Current	$T_j = 25\text{ }^\circ\text{C}$ $V_i = 35\text{ V}$		250		mA
$I_{scp}$	Short Circuit Peak Current	$T_j = 25\text{ }^\circ\text{C}$		700		mA

## L78M00AB/AC SERIES

**ELECTRICAL CHARACTERISTICS FOR L78M10XX** (refer to the test circuits,  $V_i = 16V$ ,  $I_o = 350\text{ mA}$ ,  $C_i = 0.33\ \mu\text{F}$ ,  $C_o = 0.1\ \mu\text{F}$ ,  $T_j = -40\text{ to }125\text{ }^\circ\text{C}$  (AB),  $T_j = 0\text{ to }125\text{ }^\circ\text{C}$  (AC) unless otherwise specified)

Symbol	Parameter	Test Conditions	Min.	Typ.	Max.	Unit
$V_o$	Output Voltage	$T_j = 25\text{ }^\circ\text{C}$	9.8	10	10.2	V
$V_o$	Output Voltage	$I_o = 5\text{ mA to }350\text{ mA}$ $V_i = 12.5\text{ to }25\text{ V}$	9.6	10	10.4	V
$\Delta V_o$	Line Regulation	$I_o = 200\text{ mA}$ $T_j = 25\text{ }^\circ\text{C}$ $V_i = 12.5\text{ to }30\text{ V}$ $V_i = 13\text{ to }30\text{ V}$			100 30	mV mV
$\Delta V_o$	Load Regulation	$I_o = 5\text{ to }500\text{ mA}$ $T_j = 25\text{ }^\circ\text{C}$ $I_o = 5\text{ to }200\text{ mA}$ $T_j = 25\text{ }^\circ\text{C}$			200 100	mV mV
$I_d$	Quiescent Current	$T_j = 25\text{ }^\circ\text{C}$			6	mA
$\Delta I_d$	Quiescent Current Change	$I_o = 5\text{ to }350\text{ mA}$			0.5	mA
$\Delta I_d$	Quiescent Current Change	$I_o = 200\text{ mA}$ $V_i = 12.5\text{ to }30\text{ V}$			0.8	mA
$\frac{\Delta V_o}{\Delta T}$	Output Voltage Drift	$I_o = 5\text{ mA}$		-0.5		mV/ $^\circ\text{C}$
$e_N$	Output Noise Voltage	$B = 10\text{Hz to }100\text{KHz}$ $T_j = 25\text{ }^\circ\text{C}$		64		$\mu\text{V}$
SVR	Supply Voltage Rejection	$I_o = 300\text{ mA}$ $f = 120\text{ Hz}$ $T_j = 25\text{ }^\circ\text{C}$ $V_i = 13.5\text{ to }24\text{ V}$	56			dB
$V_d$	Dropout Voltage	$T_j = 25\text{ }^\circ\text{C}$		2		V
$I_{sc}$	Short Circuit Current	$T_j = 25\text{ }^\circ\text{C}$ $V_i = 35\text{ V}$		245		mA
$I_{scp}$	Short Circuit Peak Current	$T_j = 25\text{ }^\circ\text{C}$		700		mA

**ELECTRICAL CHARACTERISTICS FOR L78M12XX** (refer to the test circuits,  $V_i = 19V$ ,  $I_o = 350\text{ mA}$ ,  $C_i = 0.33\ \mu\text{F}$ ,  $C_o = 0.1\ \mu\text{F}$ ,  $T_j = -40\text{ to }125\text{ }^\circ\text{C}$  (AB),  $T_j = 0\text{ to }125\text{ }^\circ\text{C}$  (AC) unless otherwise specified)

Symbol	Parameter	Test Conditions	Min.	Typ.	Max.	Unit
$V_o$	Output Voltage	$T_j = 25\text{ }^\circ\text{C}$	11.75	12	12.25	V
$V_o$	Output Voltage	$I_o = 5\text{ mA to }350\text{ mA}$ $V_i = 14.5\text{ to }27\text{ V}$	11.5	12	12.5	V
$\Delta V_o$	Line Regulation	$I_o = 200\text{ mA}$ $T_j = 25\text{ }^\circ\text{C}$ $V_i = 14.5\text{ to }30\text{ V}$ $V_i = 16\text{ to }30\text{ V}$			100 30	mV mV
$\Delta V_o$	Load Regulation	$I_o = 5\text{ to }500\text{ mA}$ $T_j = 25\text{ }^\circ\text{C}$ $I_o = 5\text{ to }200\text{ mA}$ $T_j = 25\text{ }^\circ\text{C}$			240 120	mV mV
$I_d$	Quiescent Current	$T_j = 25\text{ }^\circ\text{C}$			6	mA
$\Delta I_d$	Quiescent Current Change	$I_o = 5\text{ to }350\text{ mA}$			0.5	mA
$\Delta I_d$	Quiescent Current Change	$I_o = 200\text{ mA}$ $V_i = 14.5\text{ to }30\text{ V}$			0.8	mA
$\frac{\Delta V_o}{\Delta T}$	Output Voltage Drift	$I_o = 5\text{ mA}$		-1		mV/ $^\circ\text{C}$
$e_N$	Output Noise Voltage	$B = 10\text{Hz to }100\text{KHz}$ $T_j = 25\text{ }^\circ\text{C}$		75		$\mu\text{V}$
SVR	Supply Voltage Rejection	$I_o = 300\text{ mA}$ $f = 120\text{ Hz}$ $T_j = 25\text{ }^\circ\text{C}$ $V_i = 15\text{ to }25\text{ V}$	55			dB
$V_d$	Dropout Voltage	$T_j = 25\text{ }^\circ\text{C}$		2		V
$I_{sc}$	Short Circuit Current	$T_j = 25\text{ }^\circ\text{C}$ $V_i = 35\text{ V}$		240		mA
$I_{scp}$	Short Circuit Peak Current	$T_j = 25\text{ }^\circ\text{C}$		700		mA

## L78M00AB/AC SERIES

**ELECTRICAL CHARACTERISTICS FOR L78M15XX** (refer to the test circuits,  $V_i = 23V$ ,  $I_o = 350\text{ mA}$ ,  $C_i = 0.33\ \mu\text{F}$ ,  $C_o = 0.1\ \mu\text{F}$ ,  $T_j = -40\text{ to }125\text{ }^\circ\text{C}$  (AB),  $T_j = 0\text{ to }125\text{ }^\circ\text{C}$  (AC) unless otherwise specified)

Symbol	Parameter	Test Conditions	Min.	Typ.	Max.	Unit
$V_o$	Output Voltage	$T_j = 25\text{ }^\circ\text{C}$	14.7	15	15.3	V
$V_o$	Output Voltage	$I_o = 5\text{ mA to }350\text{ mA}$ $V_i = 17\text{ to }30\text{ V}$	14.4	15	15.6	V
$\Delta V_o$	Line Regulation	$I_o = 200\text{ mA}$ $T_j = 25\text{ }^\circ\text{C}$ $V_i = 17.5\text{ to }30\text{ V}$ $V_i = 20\text{ to }30\text{ V}$			100 30	mV mV
$\Delta V_o$	Load Regulation	$I_o = 5\text{ to }500\text{ mA}$ $T_j = 25\text{ }^\circ\text{C}$ $I_o = 5\text{ to }200\text{ mA}$ $T_j = 25\text{ }^\circ\text{C}$			300 150	mV mV
$I_d$	Quiescent Current	$T_j = 25\text{ }^\circ\text{C}$			6	mA
$\Delta I_d$	Quiescent Current Change	$I_o = 5\text{ to }350\text{ mA}$			0.5	mA
$\Delta I_d$	Quiescent Current Change	$I_o = 200\text{ mA}$ $V_i = 17.5\text{ to }30\text{ V}$			0.8	mA
$\frac{\Delta V_o}{\Delta T}$	Output Voltage Drift	$I_o = 5\text{ mA}$		-1		$\text{mV}/^\circ\text{C}$
$e_N$	Output Noise Voltage	$B = 10\text{Hz to }100\text{KHz}$ $T_j = 25\text{ }^\circ\text{C}$		90		$\mu\text{V}$
SVR	Supply Voltage Rejection	$I_o = 300\text{ mA}$ $f = 120\text{ Hz}$ $T_j = 25\text{ }^\circ\text{C}$ $V_i = 18.5\text{ to }28.5\text{ V}$	54			dB
$V_d$	Dropout Voltage	$T_j = 25\text{ }^\circ\text{C}$		2		V
$I_{sc}$	Short Circuit Current	$T_j = 25\text{ }^\circ\text{C}$ $V_i = 35\text{ V}$		240		mA
$I_{scp}$	Short Circuit Peak Current	$T_j = 25\text{ }^\circ\text{C}$		700		mA

**ELECTRICAL CHARACTERISTICS FOR L78M18XX** (refer to the test circuits,  $V_i = 26V$ ,  $I_o = 350\text{ mA}$ ,  $C_i = 0.33\ \mu\text{F}$ ,  $C_o = 0.1\ \mu\text{F}$ ,  $T_j = -40\text{ to }125\text{ }^\circ\text{C}$  (AB),  $T_j = 0\text{ to }125\text{ }^\circ\text{C}$  (AC) unless otherwise specified)

Symbol	Parameter	Test Conditions	Min.	Typ.	Max.	Unit
$V_o$	Output Voltage	$T_j = 25\text{ }^\circ\text{C}$	17.64	18	18.36	V
$V_o$	Output Voltage	$I_o = 5\text{ mA to }350\text{ mA}$ $V_i = 20.5\text{ to }33\text{ V}$	17.3	18	18.7	V
$\Delta V_o$	Line Regulation	$I_o = 200\text{ mA}$ $T_j = 25\text{ }^\circ\text{C}$ $V_i = 21\text{ to }33\text{ V}$ $V_i = 24\text{ to }33\text{ V}$			100 30	mV mV
$\Delta V_o$	Load Regulation	$I_o = 5\text{ to }500\text{ mA}$ $T_j = 25\text{ }^\circ\text{C}$ $I_o = 5\text{ to }200\text{ mA}$ $T_j = 25\text{ }^\circ\text{C}$			360 180	mV mV
$I_d$	Quiescent Current	$T_j = 25\text{ }^\circ\text{C}$			6	mA
$\Delta I_d$	Quiescent Current Change	$I_o = 5\text{ to }350\text{ mA}$			0.5	mA
$\Delta I_d$	Quiescent Current Change	$I_o = 200\text{ mA}$ $V_i = 21\text{ to }33\text{ V}$			0.8	mA
$\frac{\Delta V_o}{\Delta T}$	Output Voltage Drift	$I_o = 5\text{ mA}$		-1.1		$\text{mV}/^\circ\text{C}$
$e_N$	Output Noise Voltage	$B = 10\text{Hz to }100\text{KHz}$ $T_j = 25\text{ }^\circ\text{C}$		100		$\mu\text{V}$
SVR	Supply Voltage Rejection	$I_o = 300\text{ mA}$ $f = 120\text{ Hz}$ $T_j = 25\text{ }^\circ\text{C}$ $V_i = 22\text{ to }32\text{ V}$	53			dB
$V_d$	Dropout Voltage	$T_j = 25\text{ }^\circ\text{C}$		2		V
$I_{sc}$	Short Circuit Current	$T_j = 25\text{ }^\circ\text{C}$ $V_i = 35\text{ V}$		240		mA
$I_{scp}$	Short Circuit Peak Current	$T_j = 25\text{ }^\circ\text{C}$		700		mA



## L78M00AB/AC SERIES

**ELECTRICAL CHARACTERISTICS FOR L78M20XX** (refer to the test circuits,  $V_i = 29V$ ,  $I_o = 350\text{ mA}$ ,  $C_i = 0.33\ \mu\text{F}$ ,  $C_o = 0.1\ \mu\text{F}$ ,  $T_j = -40\text{ to }125\text{ }^\circ\text{C}$  (AB),  $T_j = 0\text{ to }125\text{ }^\circ\text{C}$  (AC) unless otherwise specified)

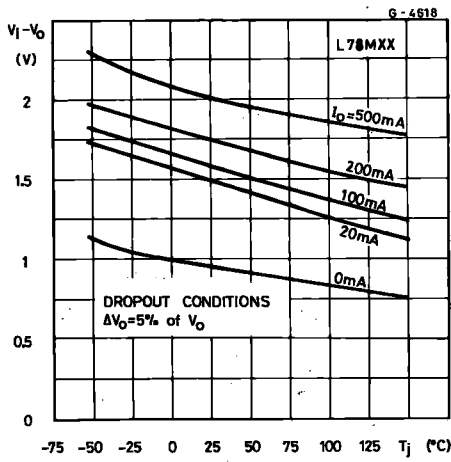
Symbol	Parameter	Test Conditions	Min.	Typ.	Max.	Unit
$V_o$	Output Voltage	$T_j = 25\text{ }^\circ\text{C}$	19.6	20	20.4	V
$V_o$	Output Voltage	$I_o = 5\text{ mA to }350\text{ mA}$ $V_i = 23\text{ to }35\text{ V}$	19.2	20	20.8	V
$\Delta V_o$	Line Regulation	$I_o = 200\text{ mA}$ $T_j = 25\text{ }^\circ\text{C}$ $V_i = 23\text{ to }35\text{ V}$ $V_i = 24\text{ to }35\text{ V}$			100 30	mV mV
$\Delta V_o$	Load Regulation	$I_o = 5\text{ to }500\text{ mA}$ $T_j = 25\text{ }^\circ\text{C}$ $I_o = 5\text{ to }200\text{ mA}$ $T_j = 25\text{ }^\circ\text{C}$			400 200	mV mV
$I_d$	Quiescent Current	$T_j = 25\text{ }^\circ\text{C}$			6	mA
$\Delta I_d$	Quiescent Current Change	$I_o = 5\text{ to }350\text{ mA}$			0.5	mA
$\Delta I_d$	Quiescent Current Change	$I_o = 200\text{ mA}$ $V_i = 23\text{ to }35\text{ V}$			0.8	mA
$\frac{\Delta V_o}{\Delta T}$	Output Voltage Drift	$I_o = 5\text{ mA}$		-1.1		mV/°C
$e_N$	Output Noise Voltage	$B = 10\text{Hz to }100\text{KHz}$ $T_j = 25\text{ }^\circ\text{C}$		110		$\mu\text{V}$
SVR	Supply Voltage Rejection	$I_o = 300\text{ mA}$ $f = 120\text{ Hz}$ $T_j = 25\text{ }^\circ\text{C}$ $V_i = 24\text{ to }34\text{ V}$	53			dB
$V_d$	Dropout Voltage	$T_j = 25\text{ }^\circ\text{C}$		2		V
$I_{sc}$	Short Circuit Current	$T_j = 25\text{ }^\circ\text{C}$ $V_i = 35\text{ V}$		240		mA
$I_{scp}$	Short Circuit Peak Current	$T_j = 25\text{ }^\circ\text{C}$		700		mA

**ELECTRICAL CHARACTERISTICS FOR L78M24XX** (refer to the test circuits,  $V_i = 33V$ ,  $I_o = 350\text{ mA}$ ,  $C_i = 0.33\ \mu\text{F}$ ,  $C_o = 0.1\ \mu\text{F}$ ,  $T_j = -40\text{ to }125\text{ }^\circ\text{C}$  (AB),  $T_j = 0\text{ to }125\text{ }^\circ\text{C}$  (AC) unless otherwise specified)

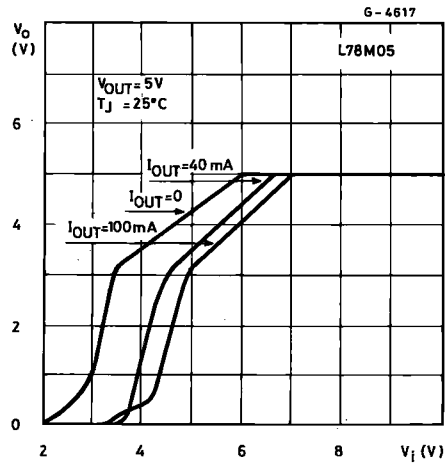
Symbol	Parameter	Test Conditions	Min.	Typ.	Max.	Unit
$V_o$	Output Voltage	$T_j = 25\text{ }^\circ\text{C}$	23.5	24	24.5	V
$V_o$	Output Voltage	$I_o = 5\text{ mA to }350\text{ mA}$ $V_i = 27\text{ to }38\text{ V}$	23	24	25	V
$\Delta V_o$	Line Regulation	$I_o = 200\text{ mA}$ $T_j = 25\text{ }^\circ\text{C}$ $V_i = 27\text{ to }38\text{ V}$ $V_i = 28\text{ to }38\text{ V}$			100 30	mV mV
$\Delta V_o$	Load Regulation	$I_o = 5\text{ to }500\text{ mA}$ $T_j = 25\text{ }^\circ\text{C}$ $I_o = 5\text{ to }200\text{ mA}$ $T_j = 25\text{ }^\circ\text{C}$			480 240	mV mV
$I_d$	Quiescent Current	$T_j = 25\text{ }^\circ\text{C}$			6	mA
$\Delta I_d$	Quiescent Current Change	$I_o = 5\text{ to }350\text{ mA}$			0.5	mA
$\Delta I_d$	Quiescent Current Change	$I_o = 200\text{ mA}$ $V_i = 27\text{ to }38\text{ V}$			0.8	mA
$\frac{\Delta V_o}{\Delta T}$	Output Voltage Drift	$I_o = 5\text{ mA}$		-1.2		mV/°C
$e_N$	Output Noise Voltage	$B = 10\text{Hz to }100\text{KHz}$ $T_j = 25\text{ }^\circ\text{C}$		170		$\mu\text{V}$
SVR	Supply Voltage Rejection	$I_o = 300\text{ mA}$ $f = 120\text{ Hz}$ $T_j = 25\text{ }^\circ\text{C}$ $V_i = 28\text{ to }38\text{ V}$	50			dB
$V_d$	Dropout Voltage	$T_j = 25\text{ }^\circ\text{C}$		2		V
$I_{sc}$	Short Circuit Current	$T_j = 25\text{ }^\circ\text{C}$ $V_i = 35\text{ V}$		240		mA
$I_{scp}$	Short Circuit Peak Current	$T_j = 25\text{ }^\circ\text{C}$		700		mA

# L78M00AB/AC SERIES

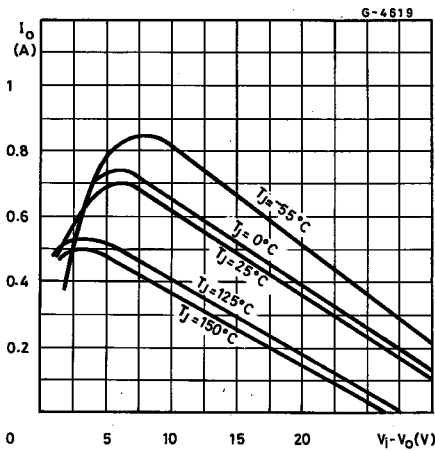
**Figure 4 :** Dropout Voltage vs. Junction Temperature.



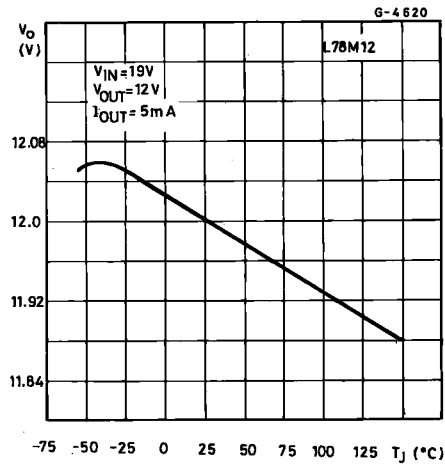
**Figure 5 :** Dropout Characteristics.



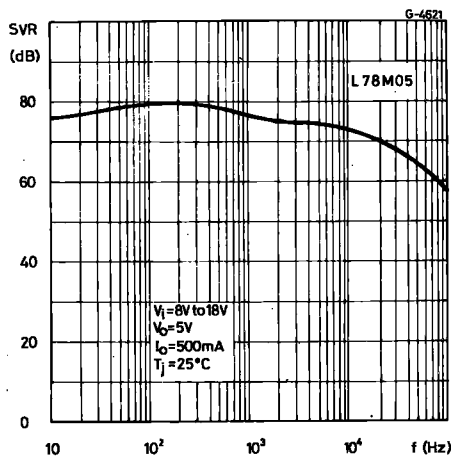
**Figure 6 :** Peak Output Current vs. Input-Output Differential Voltage.



**Figure 7 :** Output Voltage vs. Junction Temperature.



**Figure 8 :** Supply Voltage Rejection vs. Frequency.



**Figure 9 :** Quiescent Current vs. Junction Temperature.

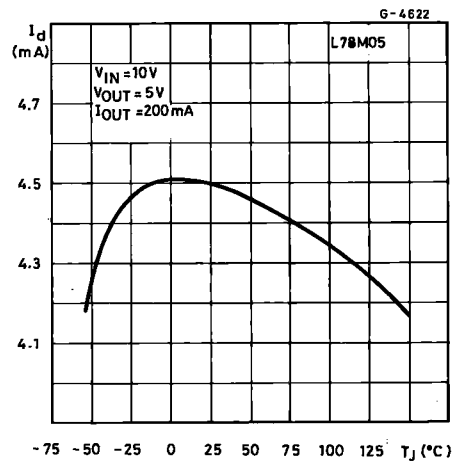


Figure 10 : Load Transient Response.

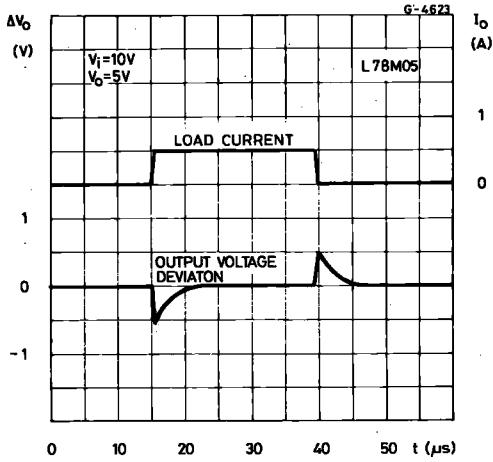


Figure 11 : Line Transient Response.

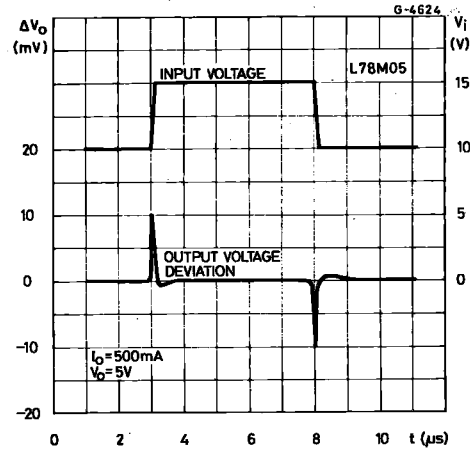
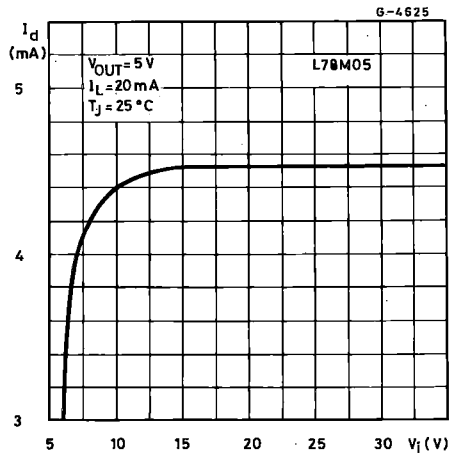


Figure 12 : Quiescent Current vs. Input Voltage.



**APPLICATIONS INFORMATION**

**DESIGN CONSIDERATIONS**

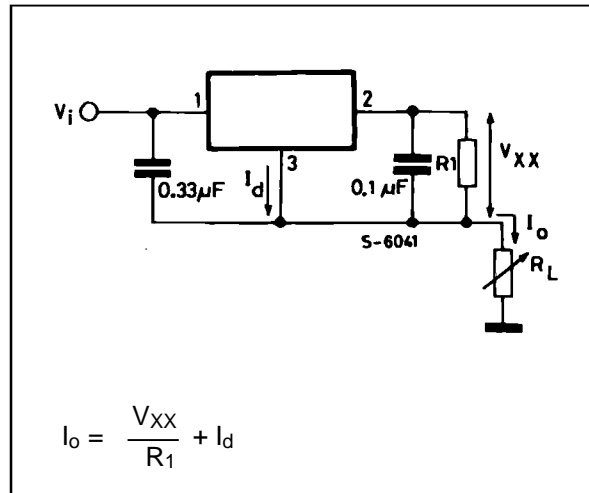
The L78M00AB Series of fixed voltage regulators are designed with Thermal Overload Protection that shuts down the circuit when subjected to an excessive power overload condition, Internal Short-Circuit Protection that limits the maximum current the circuit will pass, and Output Transistor Safe-Area Compensation that reduces the output short-circuit as the voltage across the pass transistor is increased.

In many low current applications, compensation capacitors are not required. However, it is recommended that the regulator input be bypassed

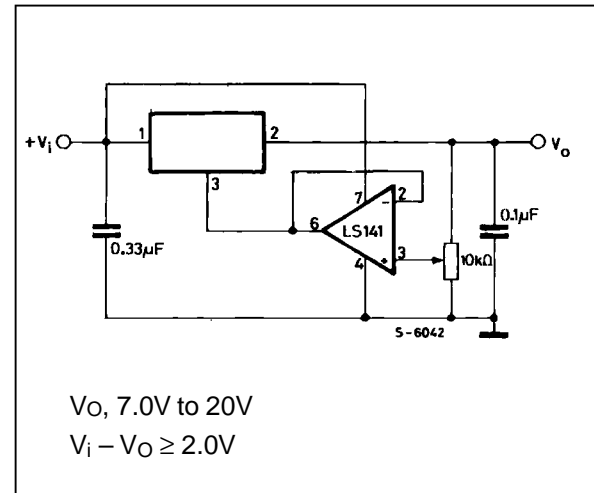
with a capacitor if the regulator is connected to the power supply filter with long wire lengths, or if the output load capacitance is large. An input bypass capacitor should be selected to provide good high-frequency characteristics to insure stable operation under all load conditions. A 0.33μF or larger tantalum, mylar, or other capacitor having low internal impedance at high frequencies should be chosen. The bypass capacitor should be mounted with the shortest possible leads directly across the regulators input terminals. Normally good construction techniques should be used to minimize ground loops and lead resistance drops since the regulator has no external sense lead.

## L78M00AB/AC SERIES

**Figure 13 :** Current Regulator.

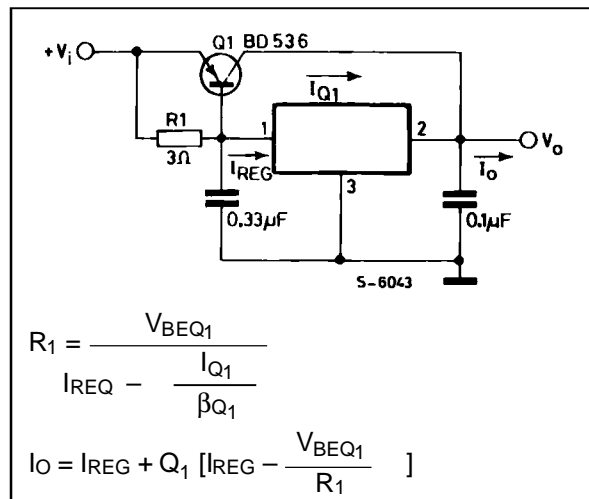


**Figure 14 :** Adjustable Output Regulator.

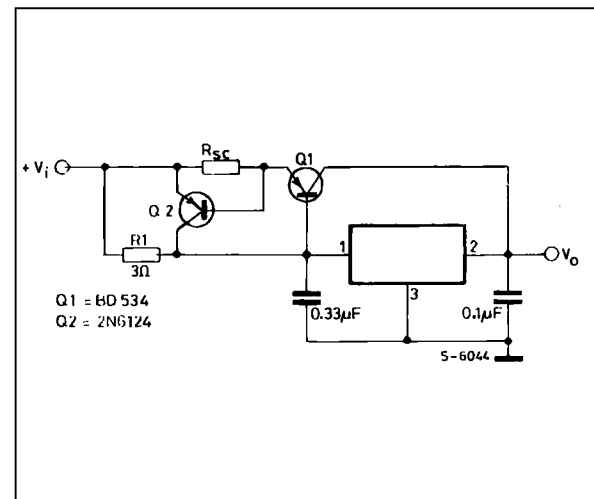


The addition of an operational amplifier allows adjustment to higher or intermediate values while retaining regulation characteristics. The minimum voltage obtainable with this arrangement is 2.0V greater than the regulator voltage.

**Figure 15 :** Current Boost Regulator.



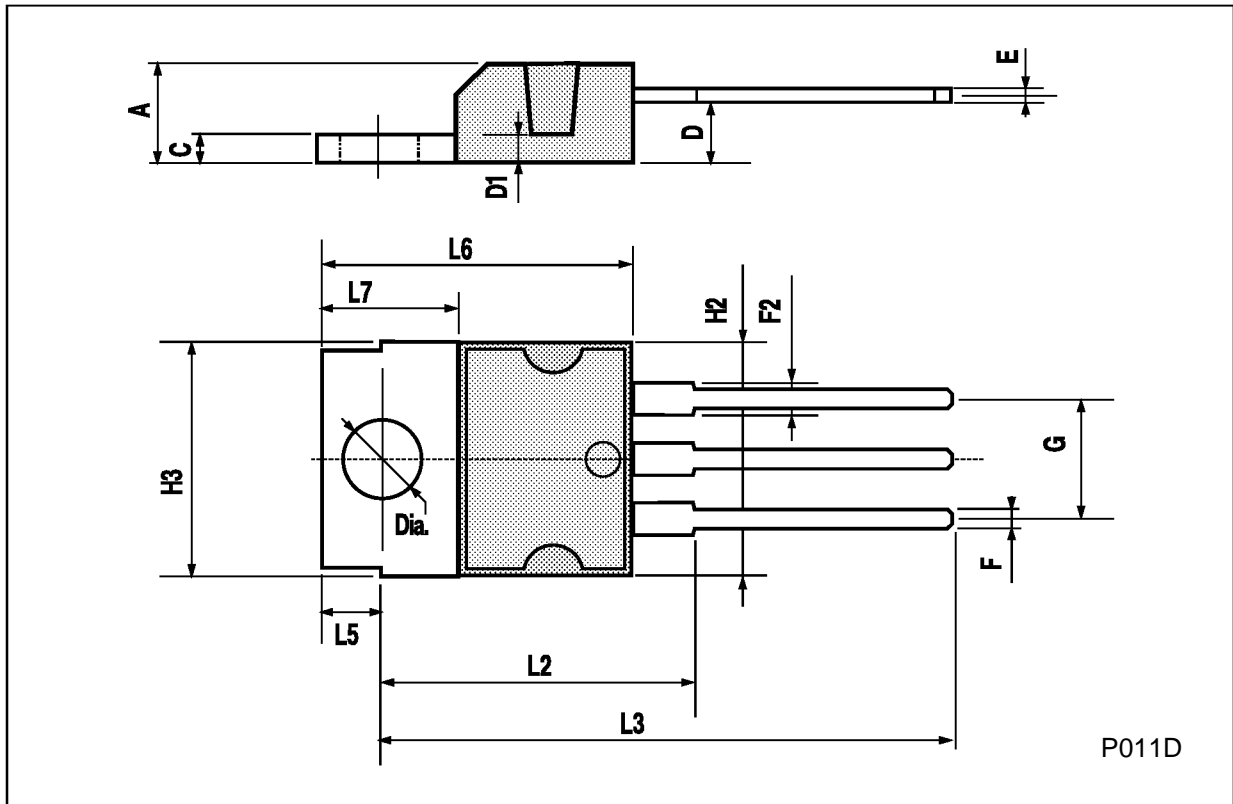
**Figure 16 :** Short-circuit Protection.



The circuit of figure 6 can be modified to provide supply protection against short circuits by adding a short-circuit sense resistor,  $R_{SC}$ , and an additional PNP transistor. The current sensing PNP must be able to handle the short-circuit current of the three-terminal regulator. Therefore, a four-ampere plastic power transistor is specified.

**TO-220 MECHANICAL DATA**

DIM.	mm			inch		
	MIN.	TYP.	MAX.	MIN.	TYP.	MAX.
A			4.8			0.189
C			1.37			0.054
D	2.4		2.8	0.094		0.110
D1	1.2		1.35	0.047		0.053
E	0.35		0.55	0.014		0.022
F	0.8		1.05	0.031		0.041
F2	1.15		1.4	0.045		0.055
G	4.95	5.08	5.21	0.195	0.200	0.205
H2			10.4			0.409
H3	10.05		10.4	0.396		0.409
L2		16.2			0.638	
L3	26.3	26.7	27.1	1.035	1.051	1.067
L5	2.6		3	0.102		0.118
L6	15.1		15.8	0.594		0.622
L7	6		6.6	0.236		0.260
Dia.	3.65		3.85	0.144		0.152

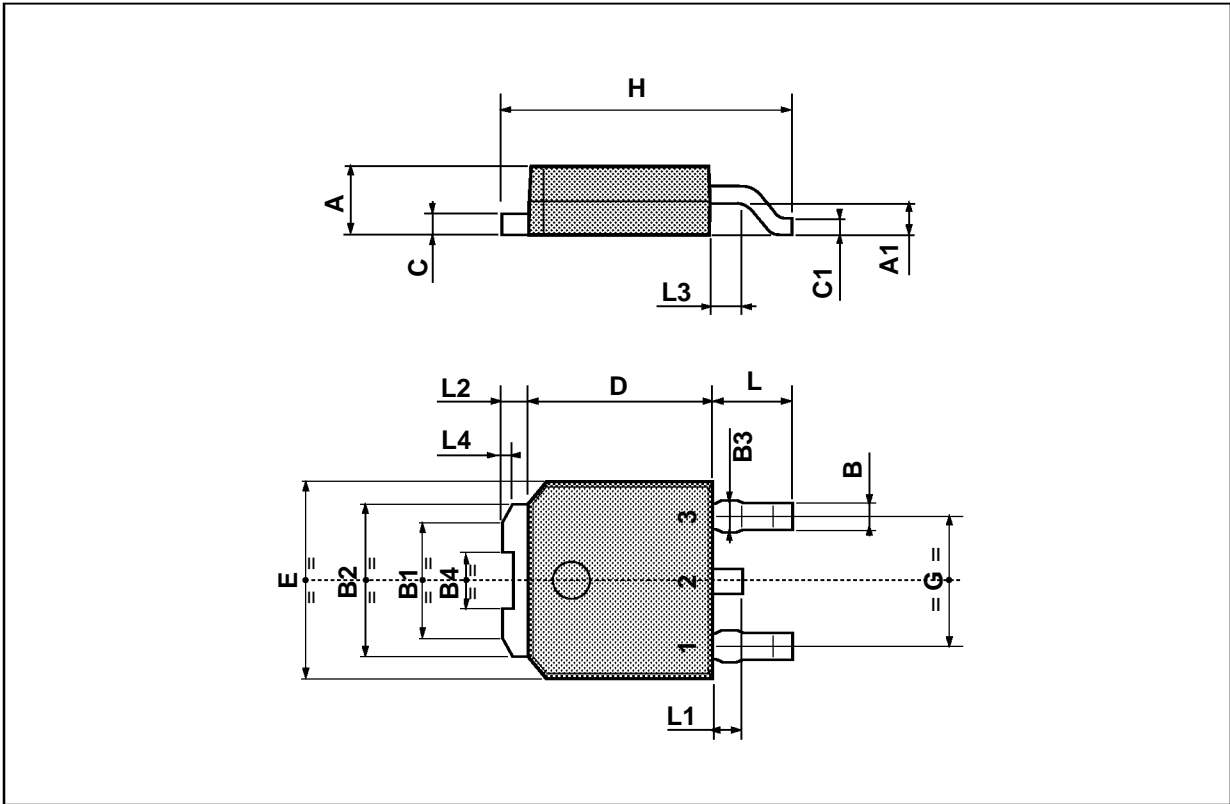


P011D

# L78M00AB/AC SERIES

## TO-252 (DPAK) MECHANICAL DATA

DIM.	mm			inch		
	MIN.	TYP.	MAX.	MIN.	TYP.	MAX.
A	2.2		2.4	0.086		0.094
A1	0.9		1.1	0.035		0.043
B	0.64		0.8	0.025		0.031
B1	3.4		3.6	0.133		0.141
B2	5.2		5.4	0.204		0.212
B3			0.9			0.035
B4	1.9		2.1	0.074		0.082
C	0.48		0.6	0.018		0.023
C1	0.45		0.6	0.017		0.023
D	6		6.2	0.236		0.244
E	6.4		6.6	0.252		0.260
G	4.4		4.6	0.173		0.181
H	9.35		10.1	0.368		0.397
L	2.55		3.05	0.100		0.120
L1	0.6		1	0.023		0.039
L2		0.8			0.031	
L3	0.8		1.2	0.031		0.047
L4	0.3		0.45	0.012		0.017



Information furnished is believed to be accurate and reliable. However, SGS-THOMSON Microelectronics assumes no responsibility for the consequences of use of such information nor for any infringement of patents or other rights of third parties which may result from its use. No license is granted by implication or otherwise under any patent or patent rights of SGS-THOMSON Microelectronics. Specifications mentioned in this publication are subject to change without notice. This publication supersedes and replaces all information previously supplied. SGS-THOMSON Microelectronics products are not authorized for use as critical components in life support devices or systems without express written approval of SGS-THOMSON Microelectronics.

© 1994 SGS-THOMSON Microelectronics - All Rights Reserved

SGS-THOMSON Microelectronics GROUP OF COMPANIES

Australia - Brazil - France - Germany - Hong Kong - Italy - Japan - Korea - Malaysia - Malta - Morocco - The Netherlands -  
Singapore - Spain - Sweden - Switzerland - Taiwan - Thailand - United Kingdom - U.S.A